

8-Port 10/100Mbps + 4-Port 802.3at PoE+ Ethernet Switch (60W)

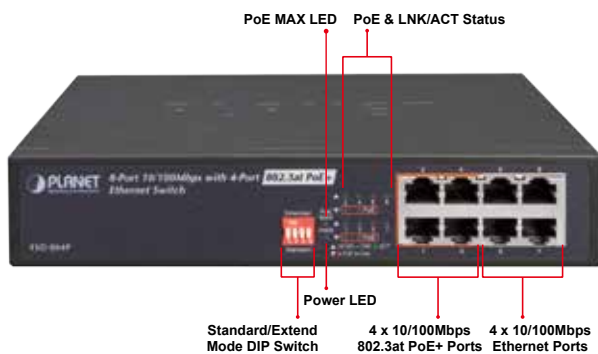

Cost-effective Centralized Power Distribution

PLANET FSD-804P is equipped with eight 10/100BASE-TX ports and four 802.3at PoE+ copper interfaces. For cost saving and flexible use of PoE power provision, half of the 10/100Mbps TP ports of the FSD-804P provide PoE power injector function which is able to drive 4 IEEE 802.3at/af compliant powered devices. For SOHO or department network, the Switch also provides a simple, cost-effective and highly-reliable network connection for data as well as power. Furthermore, it is the ideal device for bridging Ethernet and Fast Ethernet workgroups or networks.



Ethernet Data Transmit Distance Extension

The built-in solid DIP switch provides “Standard” and “Extend” operation modes. The FSD-804P operates as a normal IEEE 802.at/af PoE Switch in the “Standard” operation mode.

In the “Extend” operation mode, the FSD-804P operates on a per-port basis at 10Mbps duplex operation but can support 30-watt PoE power output over a distance of up to 200 meters overcoming the 100m limit on Ethernet UTP cable. With this brand-new feature, the FSD-804P provides an additional solution for 802.3at/af PoE distance extension, thus saving the cost of Ethernet cable installation.

Physical Port

- 8-port 10/100BASE-T Fast Ethernet RJ45 copper
- 4-port IEEE 802.3at/af PoE Injector (Port-1 to Port-4)

Power over Ethernet

- Complies with IEEE 802.3af/at Power over Ethernet end-span PSE
- Up to 4 ports of IEEE 802.3af/802.3at devices powered
- Supports PoE Power up to 30.8 watts for each PoE port
- Each port supports 53V DC power to PoE powered device
- 60-watt PoE budget
- Auto detects powered device (PD)
- Circuit protection prevents power interference between ports
- Remote power feeding up to 100m with standard mode, 200m with extended mode

Switching

- Hardware based 10/100Mbps auto-negotiation and auto MDI/MDI-X
- Flow control for full duplex operation and back pressure for half duplex operation
- IEEE 802.1Q VLAN transparency
- Hardware DIP switch for “Standard” and “Extend” mode selection; the “Extend” mode features 30-watt PoE transmit distance of 200m at speed of 10Mbps (Only for Port1 – Port4)

Hardware

- 8.5-inch desktop size, 1U height, rack mountable
- LED indicators for system power, per port PoE ready and PoE activity, speed, Link/Act
- Fanless design
- Supports Energy-Efficient Ethernet (EEE) function (IEEE 802.3az)
- Supports 4000VDC Ethernet ESD protection

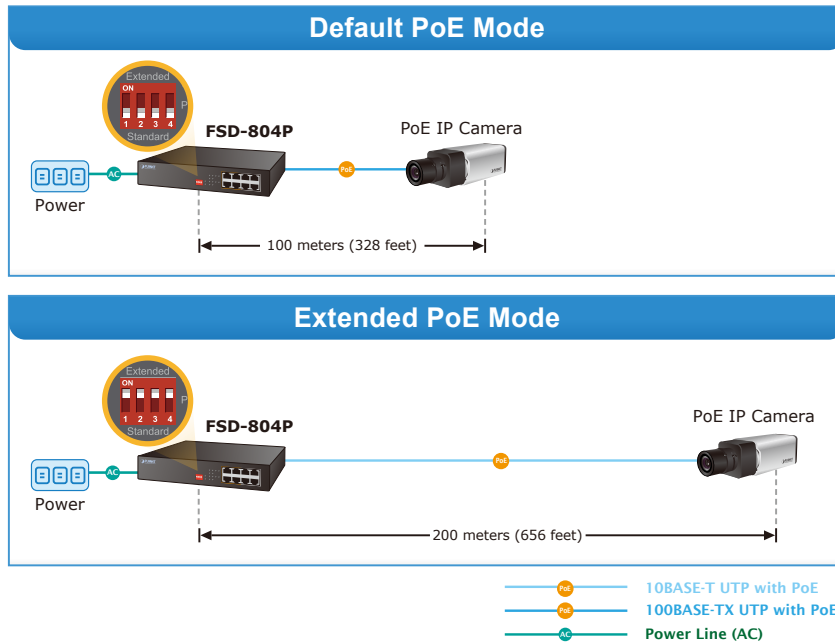

Environment-friendly, Fanless Design for Silent Operation

The FSD-804P comes with a desktop-sized, compact metal housing, making the placement of the unit convenient. It features a ventilated construction in which a cooling fan is not necessary, thereby making its operation noiseless. Moreover, the FSD-804P is able to operate reliably and stably in any environment without affecting its performance. The deployment of PoE PDs with constant power feeding can be easily and quickly done.

Easy Cable Connection

With data switching and power over Ethernet integrated into one unit, the FSD-804P reduces cabling requirements and eliminates the need for dedicated electrical outlets on the wall, ceiling or any unreachable place. A wire that carries both data and power can lower the installation costs, simplify the installation effort and eliminate the need for electricians or extension cords. With 4 PoE interfaces, the FSD-804P is ideal for small businesses and workgroups making the deployment of the PoE facility including wireless access points, IP-based surveillance camera and IP phones in any places easier, more efficient and more cost-effective.

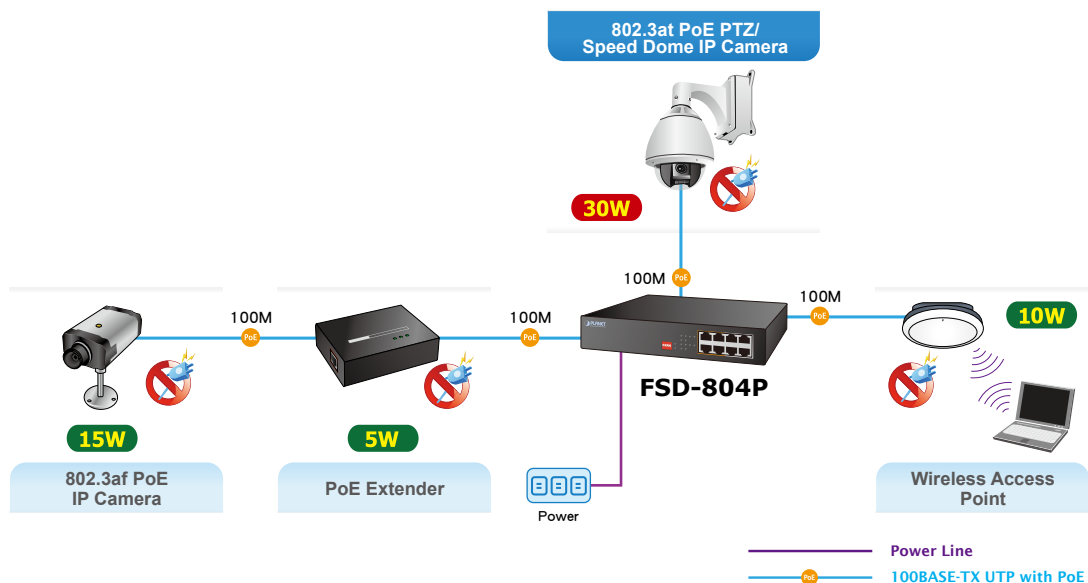

Applications

Department/Workgroup PoE Switch

Providing four 802.3at PoE+ in-line power interfaces, the FSD-804P can easily build a power source that centrally controls the enterprises' IP phone systems, IP camera systems and wireless AP systems. For instance, up to 4 cameras can be installed around the corner in the company for surveillance demands or up to 4 wireless APs can be built to have a wireless roaming environment in the office. Without the power-socket limitation, the FSD-804P makes the installation of cameras or wireless APs more easily and efficiently.

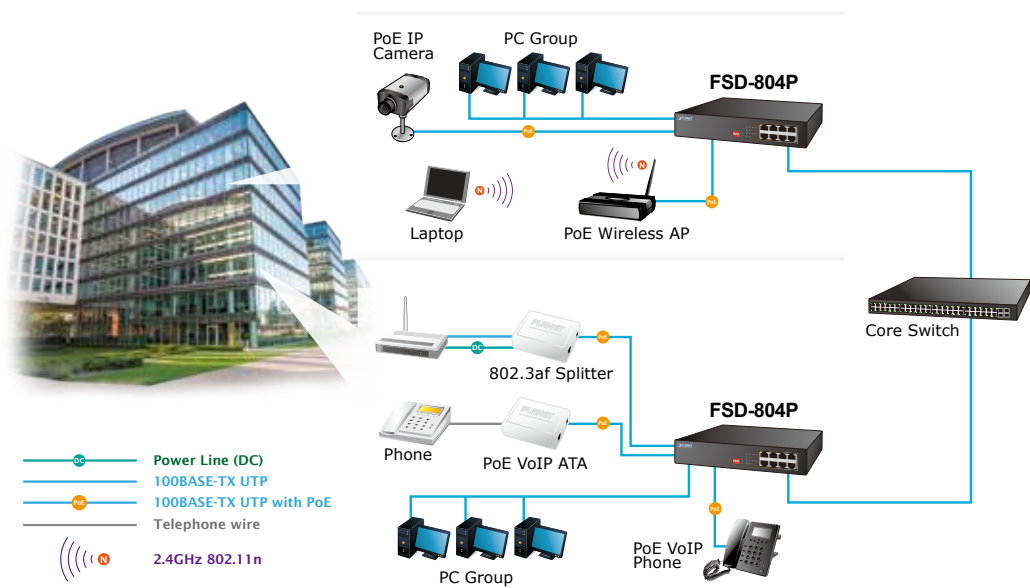
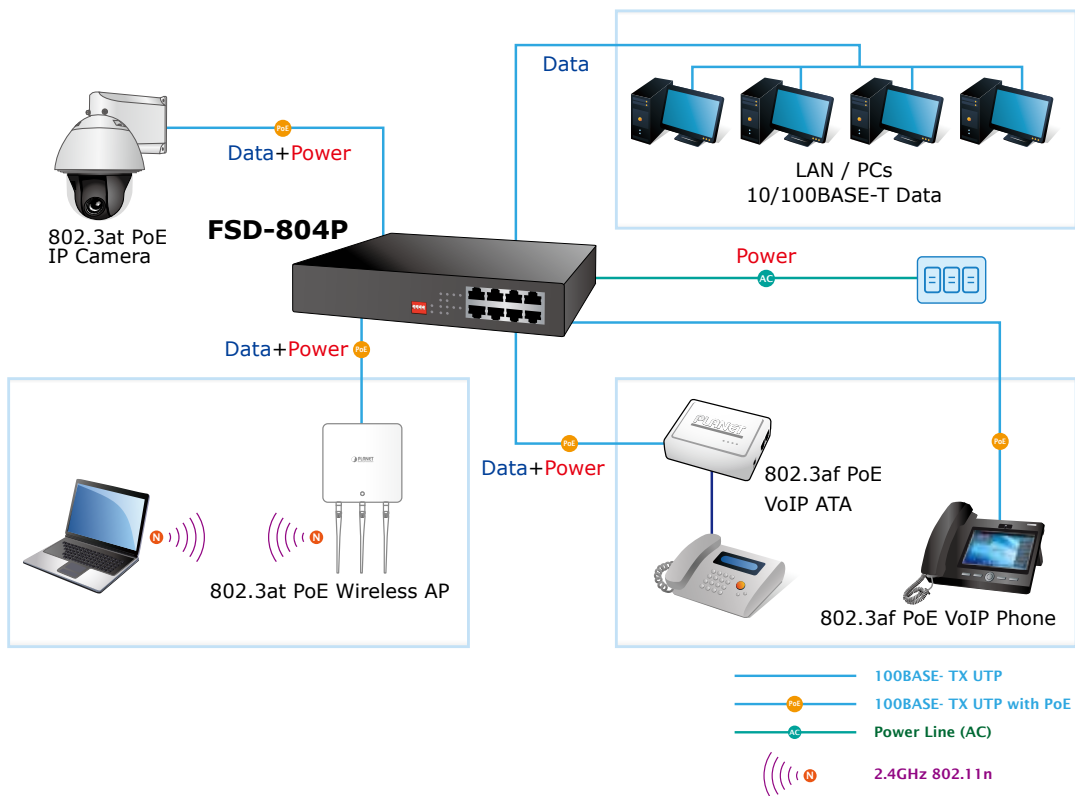

Specifications

Model	FSD-804P
Hardware Specifications	
Hardware Version	4
10/100BASE-TX MDI/MDIX Ports	8
PoE Injector Port	4 ports with 802.3at/af PoE injector function with Port-1 to Port-4
Switch Architecture	Store-and-Forward
Switch Fabric	1.6Gbps/non-blocking
Switch Throughput@64 bytes	1.19Mpps@64 bytes
MAC Address Table	1K entries, automatic source address learning and aging
Flow Control	IEEE 802.3x pause frame for full-duplex Back pressure for half-duplex
LED	System: Power (Green) PoE max. (Green) 10/100BASE-T RJ45 Interfaces: 10/100Mbps LNK/ACT (Green) PoE Interfaces: PoE-in-Use (Orange) ESD Protection 4KV DC
DIP Switch	Selectable operation mode - Standard - Extended
Dimensions (W x D x H)	215 x 133 x 42 mm (1U height)
Enclosure	Metal
Weight	880g
Power Requirements	AC 100~240V, 50/60Hz, 2A max.
Power Consumption/Dissipation	Max. 65 watts/223 BTU
Thermal Fan	Fanless
Power over Ethernet	
PoE Standard	IEEE 802.3af Power over Ethernet/PSE IEEE 802.3at Power over Ethernet Plus/PSE
PoE Power Supply Type	End-span
PoE Power Output	Per port 53V DC, 600mA. max. 30 watts
Power Pin Assignment	1/2(+), 3/6(-)
PoE Power Budget	60 watts
Max. Number of Class 2 PDs	4
Max. Number of Class 3 PDs	4
Max. Number of Class 4 PDs	2
Standards Conformance	
Regulatory Compliance	FCC Part 15 Class A, CE
Standards Compliance	IEEE 802.3 10BASE-T IEEE 802.3u 100BASE-TX IEEE 802.3x Flow control and back pressure IEEE 802.3af Power over Ethernet IEEE 802.3at Power over Ethernet Plus IEEE 802.3az Energy Efficient Ethernet (EEE)
Environment	
Operating	Temperature: 0 ~ 50 degrees C Relative Humidity: 5 ~ 95% (non-condensing)
Storage	Temperature: -10 ~ 70 degrees C Relative Humidity: 5 ~ 95% (non-condensing)

Ordering Information

FSD-804P	8-Port 10/100Mbps + 4-Port 802.3at PoE+ Ethernet Switch
----------	---

Related Products

ICA-E6260	2 Mega-pixel PoE Plus Speed Dome IP Camera with Extended Support
ICA-M3380P	H.265 3 Mega-pixel Bullet IR IP Camera with Remote Focus and Zoom
ICF-1800	HD Touch Screen Android Multimedia Conference Phone
WDAP-1750AC	1750Mbps 802.11ac Dual Band Wall Mount Enterprise Wireless Access Point
WDAP-C1750	1750Mbps 802.11ac Dual Band Ceiling-mount Enterprise Wireless Access Point
WDAP-C7200AC	1200Mbps 802.11ac Dual Band Ceiling-mount Wireless Access Point

PLANET Technology Corporation

11F., No.96, Minquan Rd., Xindian Dist., New Taipei City 231,
Taiwan (R.O.C.)
Tel: 886-2-2219-9518 Fax: 886-2-2219-9528
Email: sales@planet.com.tw www.planet.com.tw



PLANET reserves the right to change specifications without prior notice. All brand names and trademarks are property of their respective owners. Copyright © 2017 PLANET Technology Corp. All rights reserved.

FSD-804Pv4